

**CÓDIGO DE PEÇAS | CODE OF PIECES | CÓDIGO DE PIEZAS**

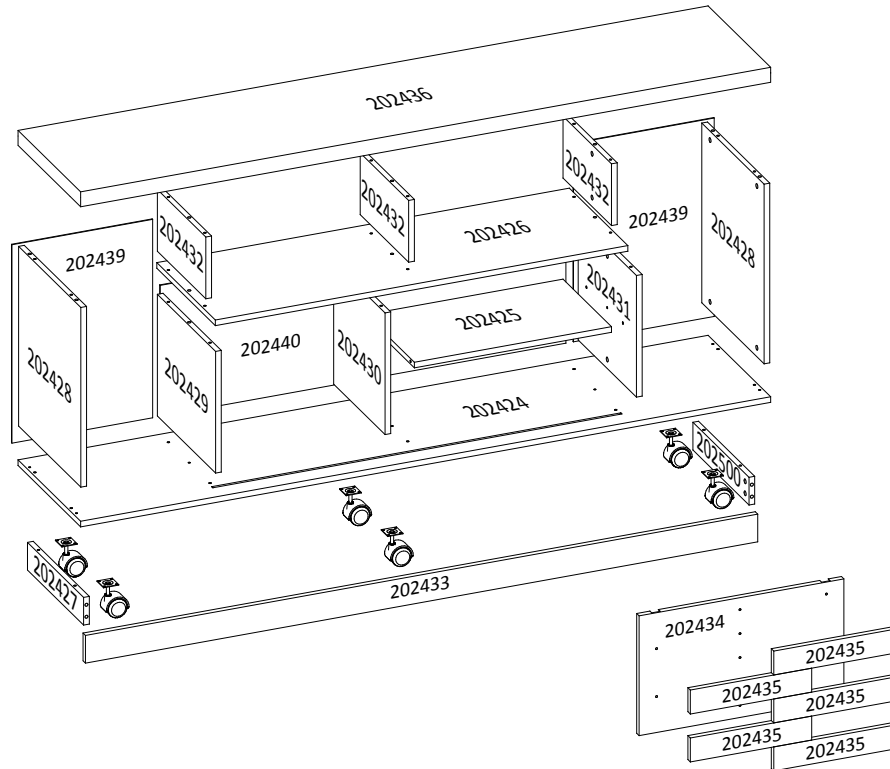

**INSTRUÇÕES | INSTRUCTIONS | INSTRUCCIONES**

- Prepare a montagem do móvel próximo ao local que ele ficará definitivamente e evite deslocá-lo depois de montado;
- Forre o chão com papelão ou similar e utilize a isomanta que vem entre as peças para evitar o contato entre elas durante a montagem;
- Monte o móvel obedecendo a ordem numérica da **seqüência de montagem (S.M.)**, identificando as peças pelo **código de peça (C.P.)** carimbado na mesma, de acordo com a tabela.
- Prepare the assembly of the close piece of furniture to the place that it will be definitively and avoid to move after done. Will be definitively and avoid to move after done;
- Cover the ground with cardboard or similar and use the isomanta that it comes among the pieces to avoid the contact among them during the assembly;
- Set up the piece of furniture obeying the numeric order of the **assembly sequence (S.M.)**, identifying the pieces by **code of piece (C.P.)** stamped in the same, in agreement with the table.
- Prepare la montaje del mobiliario proximo al lugar que estará definitivamente y evite mover después de hecho;
- Tape la suelo con cartón o similar y use la "isomanta" que viene entre las piezas para evitar el contacto entre ellos durante la montaje;
- Monte el mobiliario obedeciendo el orden numérico de la **sucesión de montaje (S.M.)**, identificando las piezas por el **código de piezas (C.P.)** de la misma estampado en esta, de acuerdo con la tabla.

**ASPECTO FINAL | FINAL ASPECT**

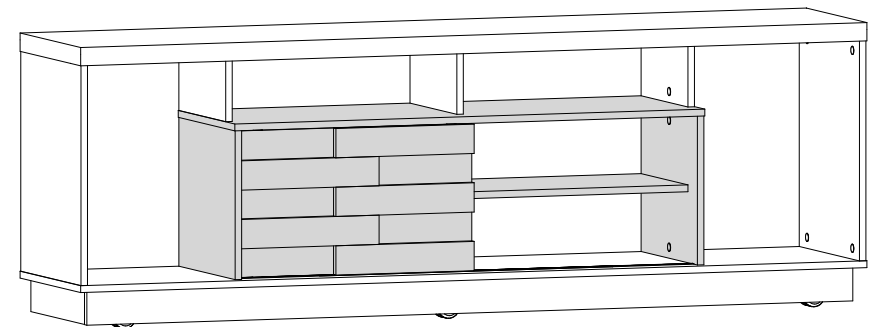

\*Dimensões em metros | *Dimensions in meters* | *Dimensiones en metros*

Espaço para Tv: → 1,820 m ⇨ 0,385 m  
Dimensão do Produto: → 1,820 m ↑ 0,625 m ⇨ 0,390 m

Edição: 09/12/2015

REF.:	PEÇAS PIECE PIEZA	MATÉRIA PRIMA	DIMENSÕES* DIMENSIONS DIMENSIONES	QUANT.
202424	Base   <i>Base</i>   <i>Base</i>	MDP	1,820 x 0,385 x 0,015	1
202425	Prateleira   <i>Intermediary top</i>   <i>Intermediario superior</i>	MDP	0,520 x 0,298 x 0,015	1
202426	Base DVD   <i>Shelf</i>   <i>Tapa del</i>	MDP	1,088 x 0,360 x 0,015	1
202427	Rodapé lateral esquerdo   <i>Left Side/right side</i>   <i>Lateral izquierda/derecha</i>	MDP	0,345 x 0,074 x 0,015	1
202500	Rodapé lateral direito   <i>Lower div. left/right</i>   <i>División inferior izquierda/dere</i>	MDP	0,345 x 0,074 x 0,015	1
202428	Lateral esquerda/direita   <i>Upper division</i>   <i>División superior</i>	MDP	0,480 x 0,383 x 0,015	2
202429	Divisão esquerda   <i>Sliding door</i>   <i>Puerta corrediza</i>	MDP	0,358 x 0,325 x 0,015	1
202430	Divisão do box   <i>View from the shelf</i>   <i>Vista de la rapisa</i>	MDP	0,325 x 0,316 x 0,015	1
202431	Divisão direita   <i>Lower panel</i>   <i>Panel inferior</i>	MDP	0,358 x 0,325 x 0,015	1
202432	Lateral e divisão DVD   <i>Central panel</i>   <i>Panel central</i>	MDP	0,298x 0,165 x 0,015	3
202433	Rodapé frontal   <i>Upper panel</i>   <i>Panel superior</i>	MDP	1,773 x 0,074 x 0,015	1
202434	Porta deslizante   <i>Side cross-bar</i>   <i>Traviesa lateral</i>	MDP	0,540 x 0,320 x 0,015	1
202435	Aplique da porta   <i>Central lane</i>   <i>Traviesa central</i>	MDP	0,320 x 0,064 x 0,015	5
202436	Tampo da tv   <i>Support panel</i>   <i>Soporte del panel</i>	MDP	1,820 x 0,385 x 0,040	1
202439	Fundo lateral   <i>Left Back</i>   <i>Fondo</i>	MDP	0,530 x 0,371 x 0,003	2
202440	Fundo central   <i>Central fund</i>   <i>Fondo central</i>	MDP	1,070 x 0,350 x 0,003	1

**ACESSÓRIOS | ACCESSORIES | ACESORIOS**

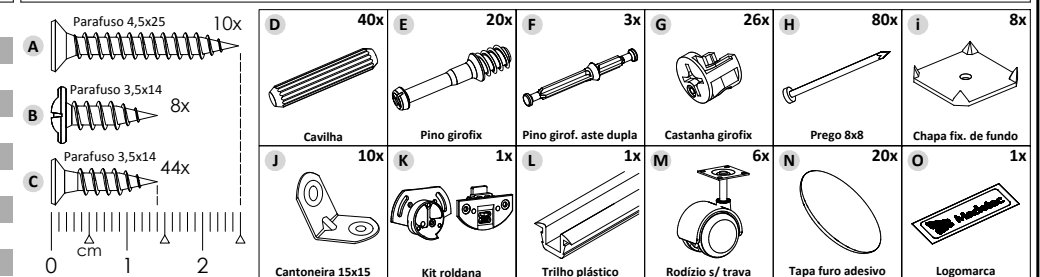

**CUIDADOS ESPECIAIS | SPECIAL CARES | CUIDADOS ESPECIALES:**

**LIMPEZA:** Pano limpo umedecido em água e sabão neutro - **BRILHO:** Flanela seca  
**CLEANING:** Clean cloth humidified in water and neutral soap - **SHINE:** Dry flannel  
**LIMPIEZA:** Tela limpia humedecida en la agua y el jabón neutro - **BRILLO:** Flanela seca

**1º PASSO | PASS | PASO**

PEÇAS  
PIECES  
PIEZAS

S.M.	C.B.
01	202424
02	202427
03	202500
04	202433

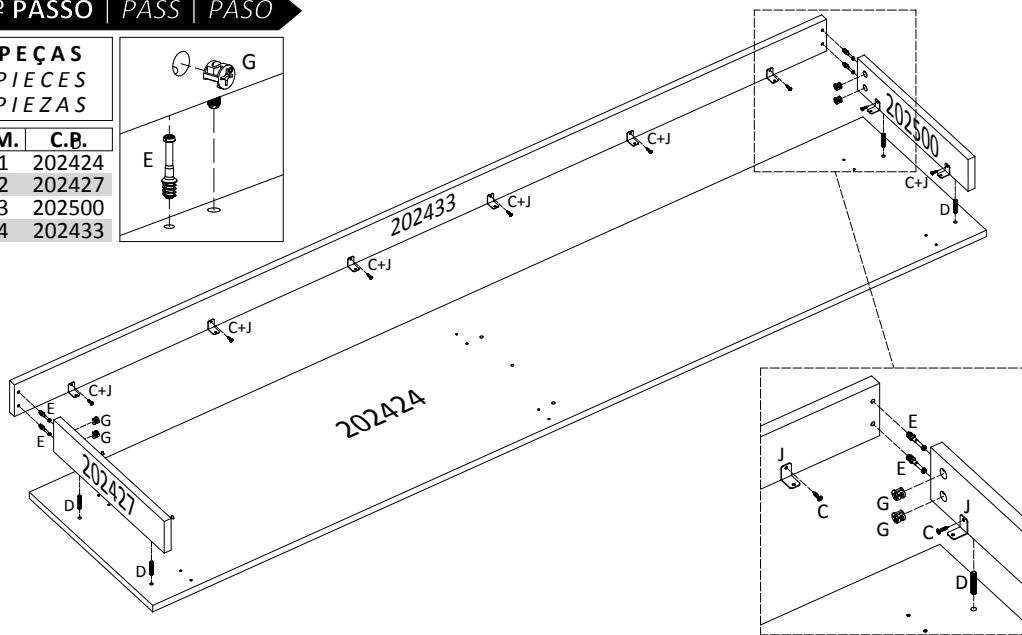

**2º PASSO | PASS | PASO**

**ATENÇÃO | ATTENTION | ATENCIÓN**

- Fixar os rodízios conforme os desenhos
- Fix the castors according to the drawings
- Fijar las ruedas según los dibujos

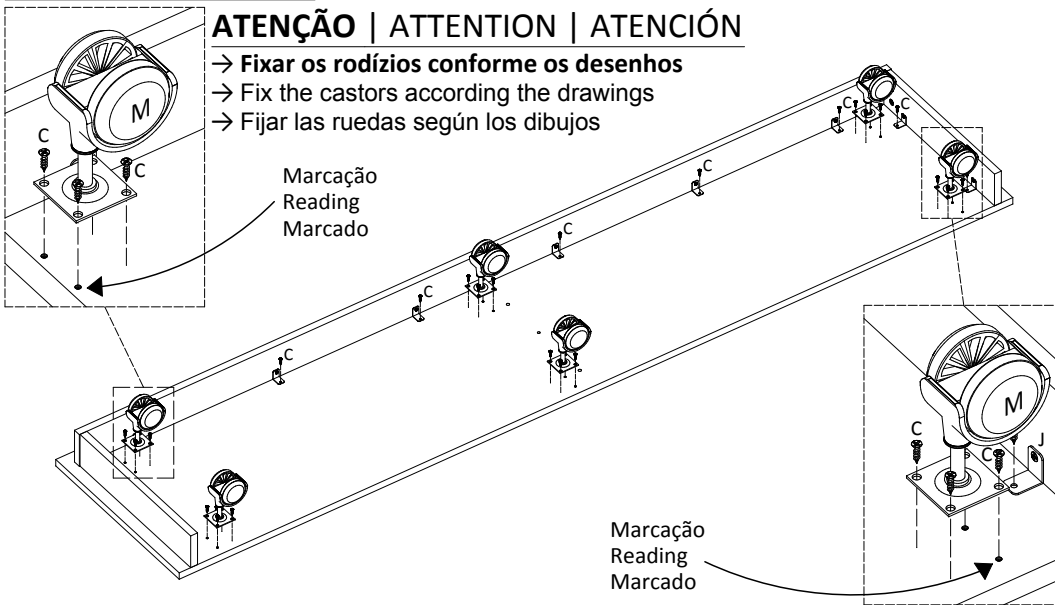

**3º PASSO | PASS | PASO**

PEÇAS  
PIECES  
PIEZAS

S.M.	C.P.
01	202425
02	202430
03	202431

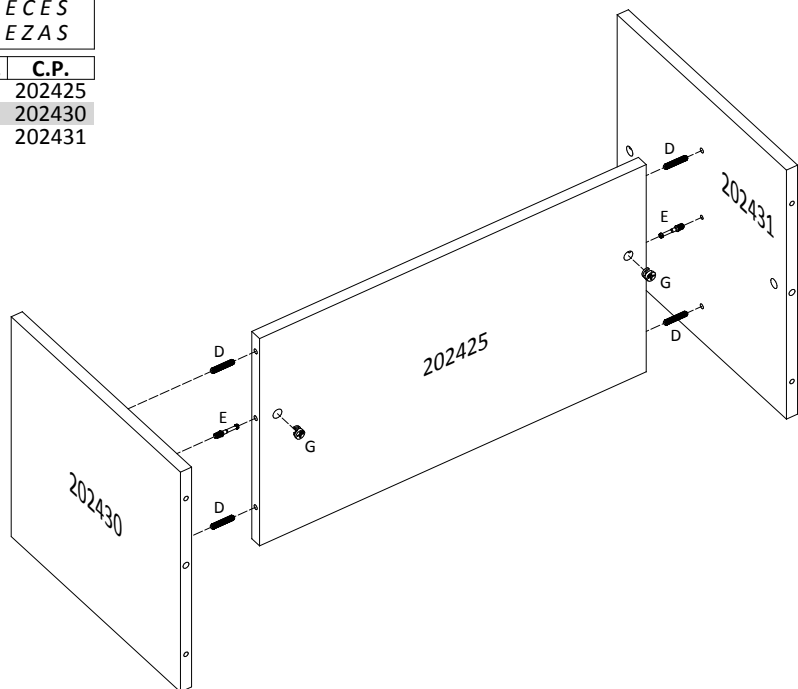

**4º PASSO | PASS | PASO**

PEÇAS  
PIECES  
PIEZAS

S.M.	C.P.
01	202428
02	202428
03	202429
04	202430
05	202431

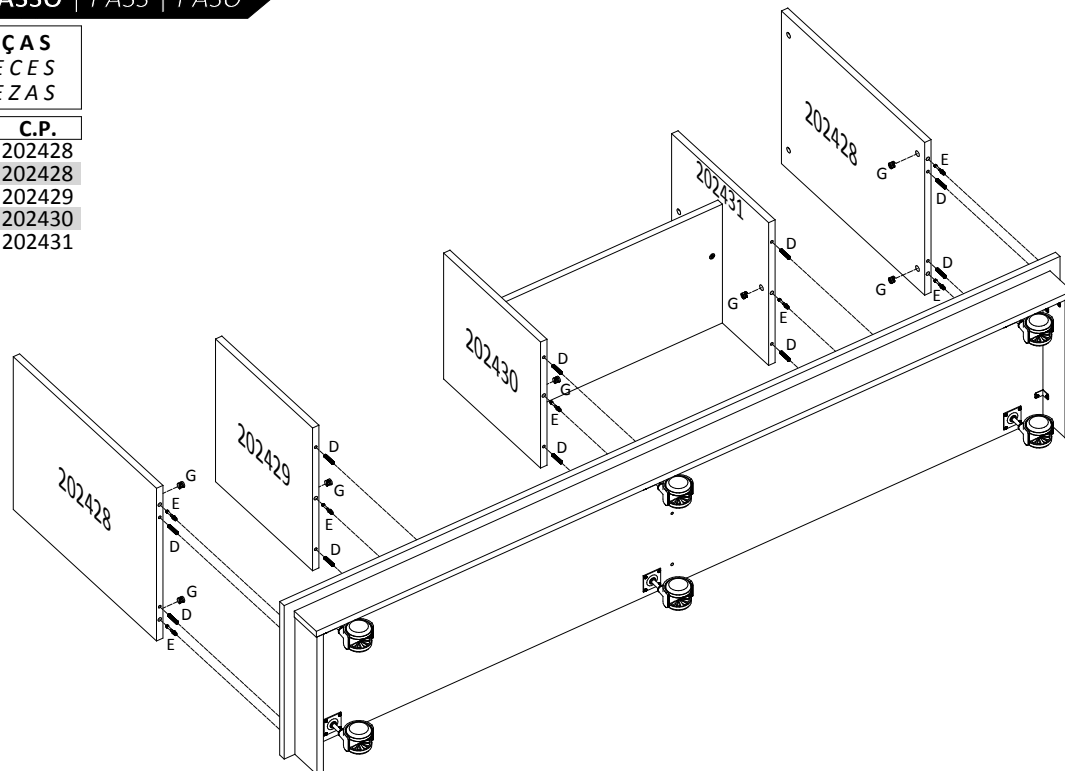

5º PASSO | PASS | PASO

PEÇAS  
PIECES  
PIEZAS

S.M.	C.P.
01	202426
02	202432
03	202432
04	202432
05	202436

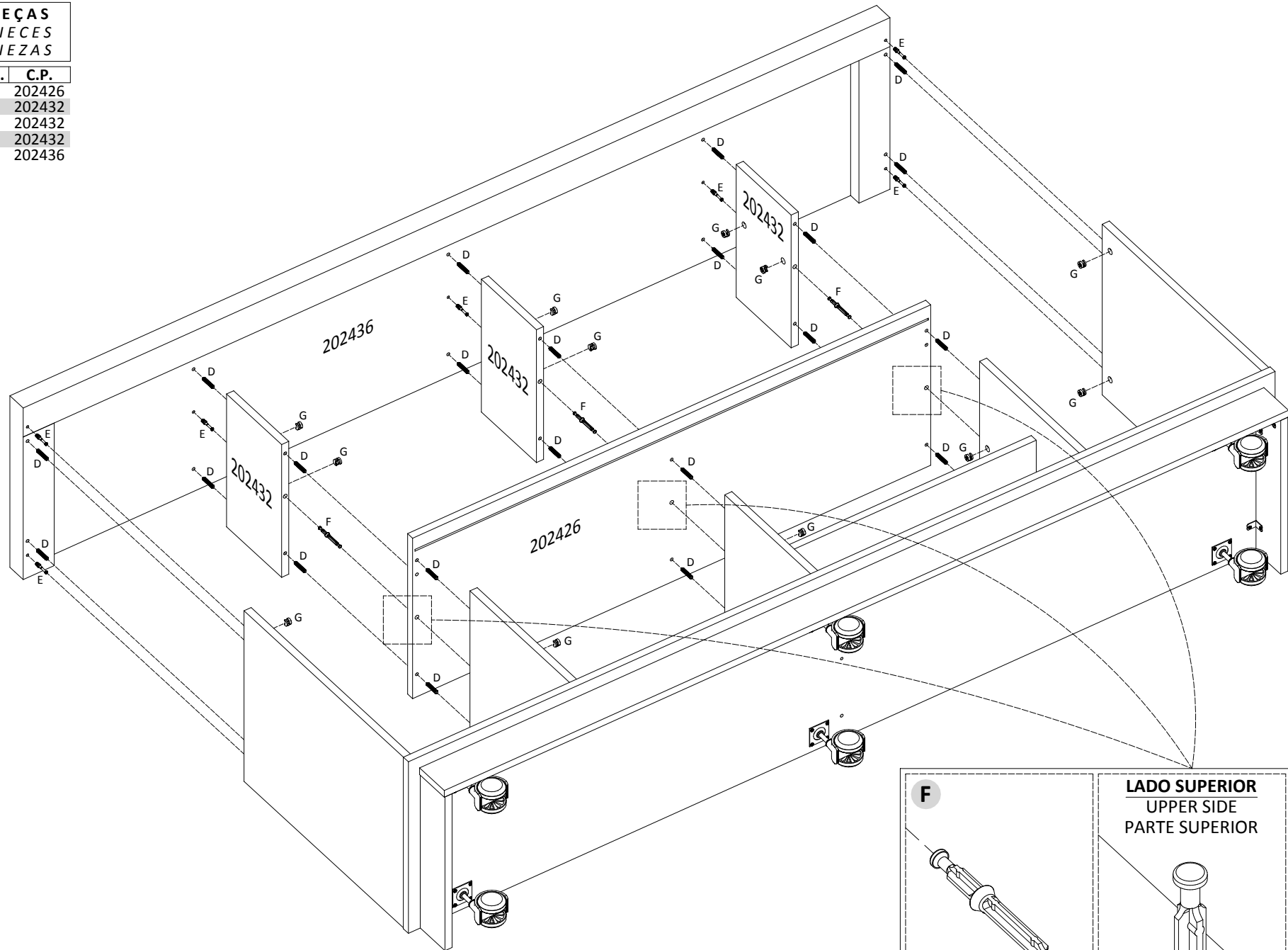

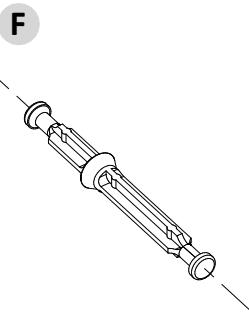
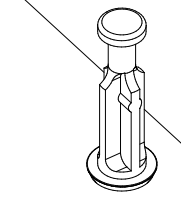
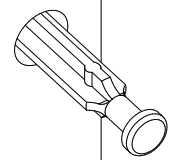
	<p><b>LADO SUPERIOR</b> UPPER SIDE PARTE SUPERIOR</p>	<p><b>LADO INFERIOR</b> BOTTOM SIDE LADO INFERIOR</p>
		

**6º PASSO | PASS | PASO**

PEÇAS  
PIECES  
PIEZAS

S.M. C.P.

01	202440
02	202439
03	202439

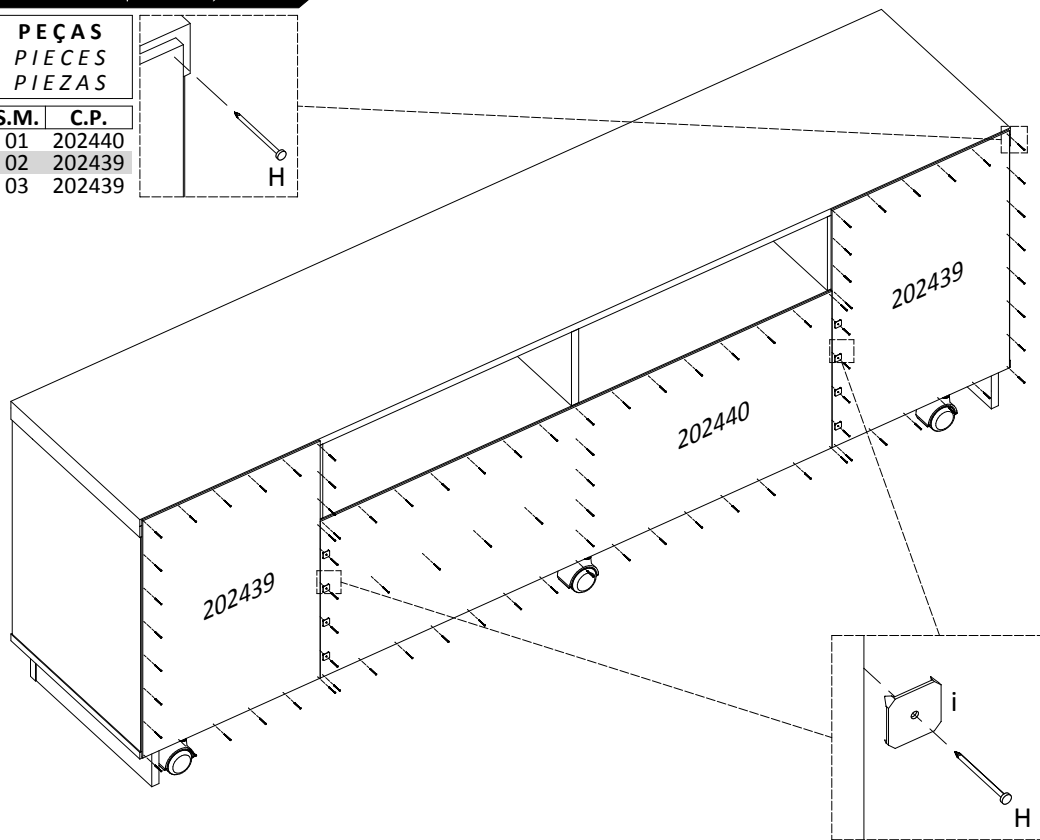
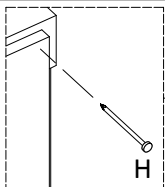

**8º PASSO | PASS | PASO**

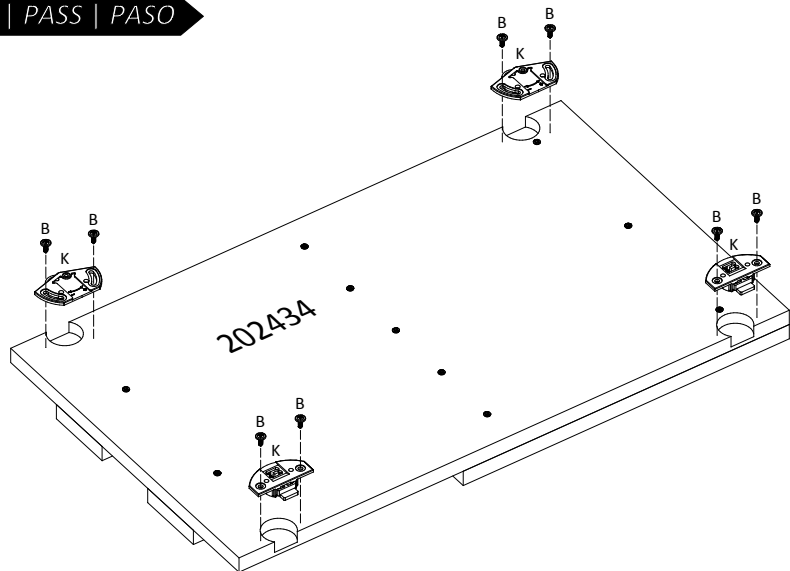

**7º PASSO | PASS | PASO**

PEÇAS  
PIECES  
PIEZAS

S.M. C.P.

01	202434
02	202435
03	202435
04	202435
05	202435
06	202435

**ATENÇÃO | ATTENTION | ATENCIÓN**

Usar as marcações para fixar as peças 202435 conforme desenho.

Use the pen markings to retain parts 202435 according to drawing.

Utilizar las marcas de rotulador para sujetar las piezas 202435 según el dibujo

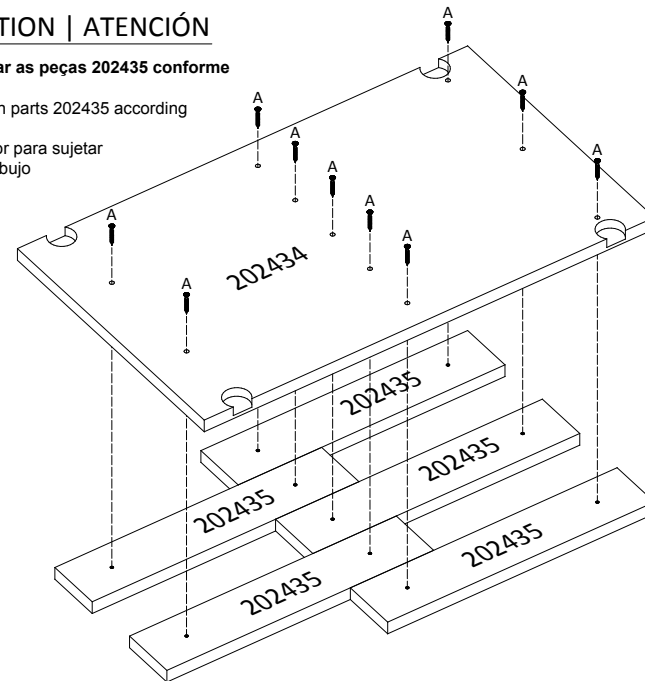

**ASPECTO FINAL | FINAL ASPECT**

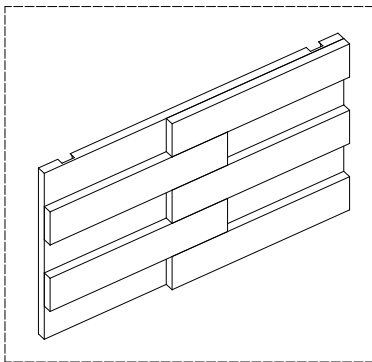

**9º PASSO | PASS | PASO**

